

Performance Evaluation of a Wood Treatment for Connections with Dowel-Type Bolts

Franz Segovia,* Pierre Blanchet, and Abdessamad Jiloul

Recent studies have shown the advantage of wood impregnation on increasing the dowel-bearing strength of black spruce wood by almost 50%. The aim of the present study was to improve the mechanical performance of a dowel-type connection through an impregnation method for black spruce wood. The results showed that wood treatments improved the mechanical performance of dowel-type connections. The dowel-bearing strength increased up to 25%, while the stiffness increased up to 52%. The increase obtained was lower in comparison with the previous studies, however. A lower polymer quantity, resulted in a shorter vacuum time, and a lower temperature polymerization used in wood treatment brought the process closer to an industrial application.

DOI: 10.15376/biores.17.2.2598-2614

Keywords: Black spruce; Dowel-bearing strength; Polymer; Stiffness; Vacuum impregnation method

Contact information: Département des Sciences du Bois et de la Forêt, Faculté de Foresterie, de Géographie et de Géomatique, Université Laval, 2425 Rue de la Terrasse, Québec, Qc, G1V 0A6 Canada;

* Corresponding author: franz.segovia-abanto.1@ulaval.ca

INTRODUCTION

Over the last few decades, the use of wood and engineered wood products for building applications has increased considerably, replacing materials such as concrete, steel, and plastic. Wood-based buildings were almost always found to have lower CO₂ emissions than comparable buildings using concrete, steel, or brick (Upton *et al.* 2008). The production and processing of wood-based building products requires less non-renewable energy consumption than many other materials used in construction (*e.g.*, concrete, steel, aluminum, or plastic) (Werner and Richter 2007). In addition, wood products can store the carbon, avoiding carbon dioxide emissions into the atmosphere during the lifetime of the building (Frühwald 2007; Falk 2009; Köhl and Frühwald 2009). Unlike the other materials mentioned, wood products come from a sustainable source, and decision-makers are increasingly asking for certified building products (Falk 2009).

The use of wood in residential buildings is well known. Architects or designers no longer hesitate to consider the use of wood in high-rise buildings. As the size of the buildings increases, fastener design is the significant limiting criterion in structural design. Consequently, the building system tends to lead to an oversized timber structure, which leads to limitations in architectural design (Lafond *et al.* 2017). The connection areas are often considered a critical point for the dimensioning of a structure because the maximum stresses are located in these areas (CSA 086-19 (2019)). Connections with mechanical fasteners play an important role in timber structures (Franke and Magnière 2014a), wherein the dowel-type connections are widely used in the building industry (Franke and Magnière 2014b). The behavior of a dowel-type connection is characterized by its stiffness (K) and

its capacity; the latter is governed by the embedment strength (dowel-bearing strength) in the wood and by the yield moment of the fastener (Franke and Magnière 2014a). The techniques for improving the dowel-type connection strength involve the study of friction between the contact surface of the fastener and wood, as well as the study of embedment performance through the improvement of the wood (Rodd and Leijten 2003). In order to study and improve the behavior of these connection types, several studies have been conducted (Gattesco 1998; Mungwa *et al.* 1999; Sawata and Yasumura 2002; Pizzi *et al.* 2006; Pantelides *et al.* 2010; Franke and Magnière 2014b; Lafond *et al.* 2016, 2017). Some research emphasized the improvement of mechanical performance of this type of connection through the wood modification using impregnation treatment (Lafond *et al.* 2016, 2017).

Chemical wood modification by impregnation is a process increasing density and hardness of wood, using monomers, oligomers or resins, which rely upon *in-situ* polymerization or curing. Wood modification has focused on the potential of altering the performance and reduce this risk of wood in service (Jones and Sandberg 2020). Despite the improvement of physical and mechanical wood properties, costs are a constraint for these treatments (Cai and Blanchet 2010). Conventional impregnation requires a long vacuum/pressure time for the chemicals to penetrate the wood structure, depending on the permeability of the wood species used (Cai and Blanchet 2011; Rowell 2012). Usually, wood modification treatments are performed to control wood hygroscopicity and to avoid biological deterioration of wood (Li *et al.* 2010; Rahman *et al.* 2010; Simsek *et al.* 2010; Sun *et al.* 2013). One of the main factors of the impregnation treatment is the chemical agent. There are several chemical agents on the construction market for different benefits such as hygroscopicity control, mechanical improvement of wood and wood surface, fire resistance, and UV stability (Shi *et al.* 2007; Bergman *et al.* 2009; Devi *et al.* 2013; Devi and Maji 2013). Polymerization of chemical agents is performed by methods such as radiation (gamma radiation and electron beam), temperature sensitive catalysts (Hill 2006; Rowell 2012), and high-temperature treatment (Sun *et al.* 2013).

Black spruce wood represents 12% of Canada's softwood inventory. It is extensively used for construction industry, due to small knot size and the long and strong attributes of the fibers. Black spruce wood is extremely impermeable (heartwood) and moderately impermeable (sapwood). Different anatomical characteristics affect gas or liquid permeability. Ray cell lumen diameter, end-wall pit number and diameter, ray cell length, vessel frequency, and both vessel and fiber diameter and length affect the depth of fluid flow (Ahmed and Chun 2009).

Wood modification with methyl methacrylate increased the compressive and flexural strength of the wood, while that with vinyl azlactone increased impact strength from 30% to 54%, and stiffness from 27% to 44% (Rowell 2012). Hamideh *et al.* (2014) reported an increase of stress-carrying capacity of L-type joint using furfurylated beech wood and epoxy resin. Rahman (2018) obtained an increase of stiffness, modulus of elasticity, and modulus of rupture of raw wood through of the impregnation method with *N,N*-dimethylacetamide polymer. Lafond *et al.* (2016) also obtained an increase of the dowel-bearing strength of nearly 50% with the impregnation of an acrylate polymer into black spruce wood.

The goal of this research was the assessment of wood impregnation treatments on improving the mechanical performance of a connection with dowel-type fastener in black spruce wood beams. The approach involved the wood treatment in the assembly area using a capillary impregnation method and an impregnation under vacuum method. The effects

of wood treatments and bolt diameters on dowel-bearing strength and stiffness along parallel and perpendicular direction of the grain were studied. An analysis of the chemical retention and the penetration depth of the polymer into the wood structure was also performed.

EXPERIMENTAL

Materials

The wood material used was black spruce (*Picea mariana* (Mill) B.S.P) obtained from Résolu Produits Forestiers, Québec, Canada. Black spruce wood used for test specimens was kiln-dried and heat-treated. The test specimens were cut into the dimensions 140 mm × 140 mm × 38 mm (L × T × R) as shown in Fig. 1. The test specimens were obtained from defect-free wood (e.g., pith, knots, cross grain, or other natural or manufacturing characteristics). A total of three holes with 11, 13.5, or 17 mm diameters were drilled in the radial direction, in the longitudinal-tangential plane for each specimen.

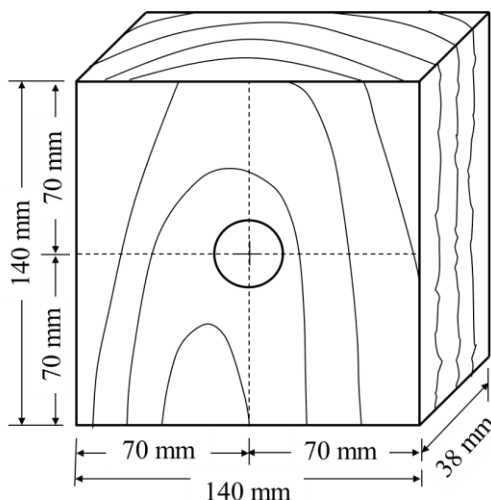

Fig. 1. Test specimen dimensions of black spruce for dowel-bearing test in direction parallel and perpendicular to the grain

Methods

Chemicals

The polymer for wood treatment was a formulation inspired by the “Michael addition” (Tokoroyama 2010), which is a reaction that allows the creation of covalent bonds between two components. Two-part impregnation formulations with a high solids content (~95%) were prepared. The formulation was optimized to reach an initial viscosity after mixing of the two components of 10 cP (mPa.S) at 25 °C. The curing time was approximately 7 d. Polymerization proceeded at room temperature. The impregnation formulation is currently the subject of a patent process; for this reason, the information provided is limited.

Impregnation process

To optimize the strategy proposed by Lafond *et al.* (2016, 2017), two wood treatments were used. Both treatments used a lower quantity of polymer for impregnation,

a shorter wood treatment time, and a lower polymerization temperature of 20 ± 3 °C (room temperature) compared to the impregnation method used by Lafond *et al.* (2017). The first treatment was the capillary impregnation method (T1), which is based on the penetration of a liquid into dry wood under the influence of capillary forces. The test specimen hole was closed on the side and was filled with the polymer. After 30 min, the excess polymer was removed. Finally, the test specimens were placed in the conditioning chamber at 20 °C and 65% relative humidity (RH) for 7 d until the polymerization of the polymer. The second wood treatment was the impregnation under vacuum method (T2). This method has proven to be more effective. Previous studies indicate that the application of vacuum removes air from the wood pores, creating a pressure gradient between the inside and the outside (surface). This gradient allows a greater amount of fluid to enter vessels wood than under capillary forces alone (Fito 1994; Fito and Pastor 1994; Panarese *et al.* 2016). The test specimen hole was also closed on the side. The test specimen was placed into the desiccator as shown in Fig. 2. The hole was filled with the polymer. The test specimen was submitted under a vacuum of 50 mbar using a vacuum pump for 1 min (Fig. 2). Finally, the excess polymer was removed, and the test specimen was placed in the conditioning chamber at 20 °C and 65% RH for 7 d until the polymer was cured. The results of the wood treatment were compared to non-treated wood (NT).

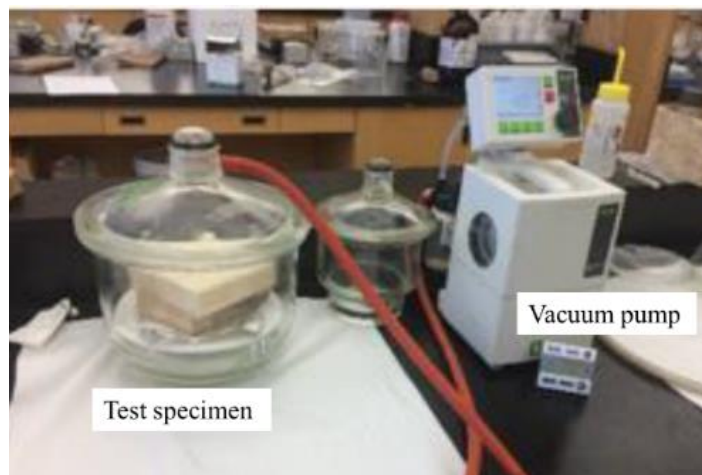

Fig. 2. Wood treatment by impregnation vacuum method (T2)

Moisture content and oven-dry specific gravity

The test specimens were conditioned at 20 °C and 65% RH until a constant mass was obtained. After performing dowel-bearing strength tests, a sample of each test specimen was obtained to determine the sample mass. The samples were placed in the oven at 103 ± 2 °C to determine the oven-dry mass. According to the ASTM D4442-16 (2016) test method, the moisture content was determined, while the oven-dry specific gravity of each sample was determined following to ASTM D2395-14 (2014) standard.

Determination of chemical retention (CR)

Test specimens were weighed before and after each wood treatment to determine the chemical retention. The weighing of treated test specimen was performed after the polymer had fully been polymerized (7 days). Percentage CR was defined as the mass of

the treated specimen minus their mass before impregnation, over their mass before impregnation by 100 (Cai and Blanchet 2010; Lafond *et al.* 2016).

Determination of polymer penetration

Determination of polymer penetration in black spruce wood was performed using a SKYCSAN 1272 Micro-CT scanner (Bruker microCT, Kontich, Belgium). Wood samples of 20 mm × 20 mm × 20 mm were treated by both impregnation methods. After polymerization, cylindrical samples of 10 mm in diameter and 10 mm in height were obtained (Fig. 3). Cylindrical samples were obtained using a wood hollow drill of 10 mm of inner diameter installed in a bench drill. The surface of the cylindrical sample was oriented in a tangential or radial transverse plane. X-rays with an X-ray tube at an accelerating voltage of 50 kV and a current of 80 μ A were generated. Cylinder samples were scanned over 180° with a rotation step of 0.2°. X-rays were detected with a 16 Mpixel (4904 × 2688 pixels) CCD camera (Bruker microCT, Kontich, Belgium). Raw X-ray attenuation data were reconstructed into data sets consisting of sequential 2D cross-sections using NRecon software version 1.7.4.2 (Bruker microCT, Kontich, Belgium). The images were analyzed and visualized using CTAn and CTVol software (Bruker microCT, Kontich, Belgium). The images were binarized, randomized, and underwent thresholding.

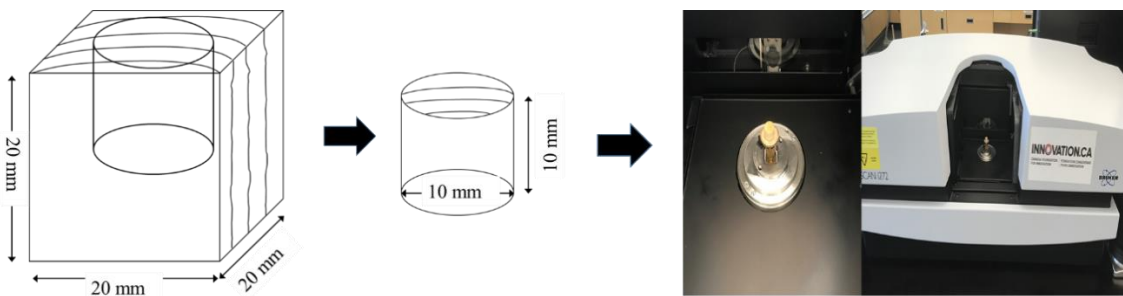

Fig. 3. Schematic view preparation of cylindrical sample in tangential direction for MicroCT scan obtained from a sample treated by impregnation vacuum method (T2)

Dowel-bearing strength

Tests in the directions parallel and perpendicular to the grain following ASTM D5764-97a (2018) test method using the full-hole testing setup were performed. The tests were conducted on an MTS Alliance RT/50 (MTS System Corporation, Eden Prairie, MN, USA) testing machine with a 50 kN load cell. The test specimen was placed in the testing machine, and a bolt of 9.5 mm, 12.7 mm, or 15.9 mm diameter was inserted into the pre-drilled hole of 11 mm, 13.5 mm, or 17 mm, respectively. The bolts conformed to SAE J429 (Society of Automotive Engineers) Grade 5 specification and obtained from a local supplier (Québec Bolts Inc., Québec, Canada). A compressive load was applied to the ends of the dowel using a setup as shown in Fig. 4. A uniform deformation rate of 1 mm/min was employed until a maximal displacement of 5 mm was reached during the test. The movement of the moving crosshead of the MTS testing machine allowed the dowel displacement to be measured.

Dowel-bearing strength (σ_{\max}) and the stiffness (k_s) were determined using the methodology described by Lafond *et al.* (2017). The ultimate loads and the load-displacement curve were recorded using TextWorks software (MTS System Corporation, Eden Prairie, MN, USA).

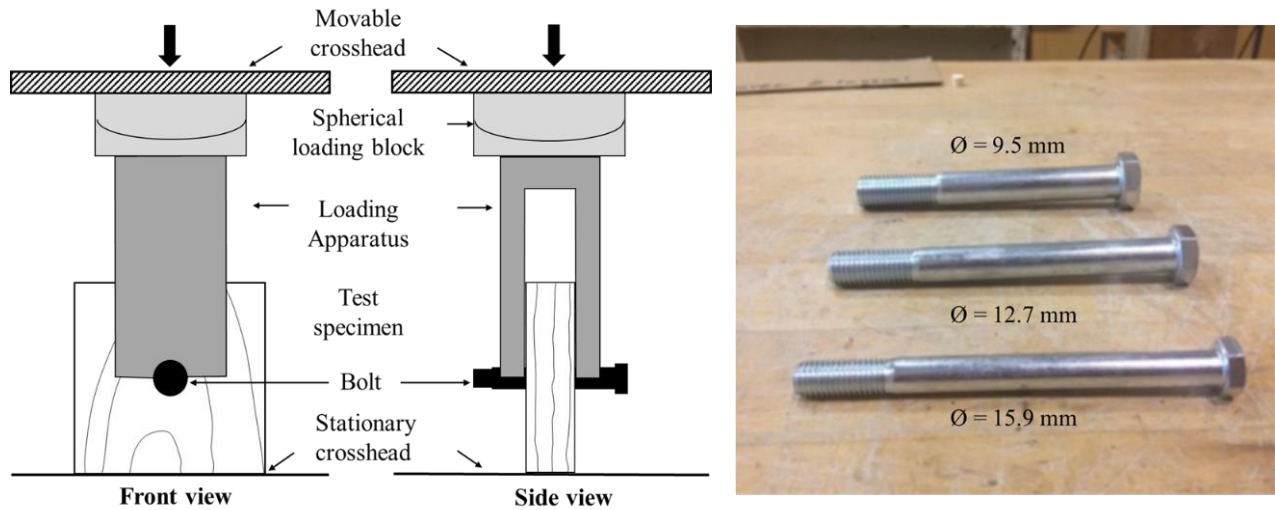

Fig. 4. Testing device to determine dowel-bearing strength following to ASTM D5764 (adapted from ASTM D5764-97a (2018))

Statistical analysis

A factorial design was used for the data analysis of the dowel-bearing strength and the stiffness in parallel and perpendicular directions to the grain. The factors were wood treatment (NT, T1, T2), bolt diameter (D1, D2, D3), and loading direction (0° , 90°). The first design evaluated the effect of wood treatment and bolt diameter as well as their interaction, by applying a load in a direction parallel to the grain.

The second design evaluated the effect of wood treatment and loading direction as well as the interaction between them, for the D2 bolt diameter. An analysis of variance (ANOVA) ($p < 0.05$) on dowel-bearing strength and on stiffness results was performed to determine significant differences between treatments. The results were analyzed using SAS software program (SAS Institute Inc., Cary, NC, USA, v. 9.4).

RESULTS AND DISCUSSION

Chemical Retention

The chemical retention results of test specimens according to the wood treatment are shown in Table 1. The chemical retentions of polymer using the impregnation vacuum method (T2) for test specimens with a pre-drilled hole diameter of 11 and 13.5 mm were higher. Meanwhile, for test specimens with pre-drilled hole diameter of 17 mm, there were no significant differences between both wood treatments. In general, chemical retention was lower than the results obtained by Lafond *et al.* (2016). This was mainly due to a smaller amount of surface impregnated, which was the surface of the pre-drilled hole. Consequently, the amount of polymer used for each wood treatment was lower.

The chemical retention results could also be explained by the lower permeability of black spruce wood compared to other species such as fir or pine (Veer 1955; Perré 1987). Previous studies such as Perré (1987) indicate longitudinal intrinsic permeability values ($\times 10^{-12} \text{ m}^2$) of 0.02 to 0.2 for spruce and 0.07 and 0.15 for Scots pine and maritime pine, respectively. Meanwhile in radial flow, intrinsic permeability values ($\times 10^{-16} \text{ m}^2$) were 0.03

for spruce and 0.42 and 8.6 for Scots pine and maritime pine, respectively. Chemical retention is directly related to total polymer viscosity; however, a low viscosity of the polymer can hardly allow good chemical retention (Veer 1955). Due to the fast polymerization of the solution, the application of a long-time vacuum was not required. Moreover, the application of the vacuum-pressure impregnation method was discarded, which could be more effective (Chernenko 2017).

Table 1. Effect of Wood Treatment on the Average Chemical Retention for Each Specimens Group

Test Specimen	Number of Specimens	Moisture Content (%)	Specific Gravity			Chemical Retention ¹ (%)		
			D1	D2	D3	D1	D2	D3
Non-treatment Wood	90	12.7	0.524 (6.07%) ²	0.512 (4.97%)	0.506 (4.88%)	---	---	---
Treated by Capillary Impregnation	90	12.6	0.496 (6.15%)	0.514 (6.77%)	0.506 (2.73%)	0.47 ^{Aa}	0.67 ^{Ba}	0.85 ^{Ca}
Treated by Impregnation under Vacuum	90	12.9	0.511 (5.96%)	0.537 (3.58%)	0.499 (4.66%)	0.75 ^{Ab}	0.88 ^{ABb}	0.91 ^{Ba}

¹Averages followed by the same letter are not significantly different at the 5% probability level. Uppercase letters (A, B, and C) are for comparison the chemical retention values between hole diameters (D1, D2, and D3). Lowercase letters (a, b) are for comparison the chemical retention values between wood treatments.

²(COV): Coefficient of variation of specific gravity

Polymer Penetration

The penetration depth of the polymer into the wood in the transverse and radial plane was determined using an SKYCSAN 1272 Micro-CT scanner. Figure 5 shows 2D images of the polymer penetration into wood treated by the vacuum impregnation method at different depths in the transverse plane.

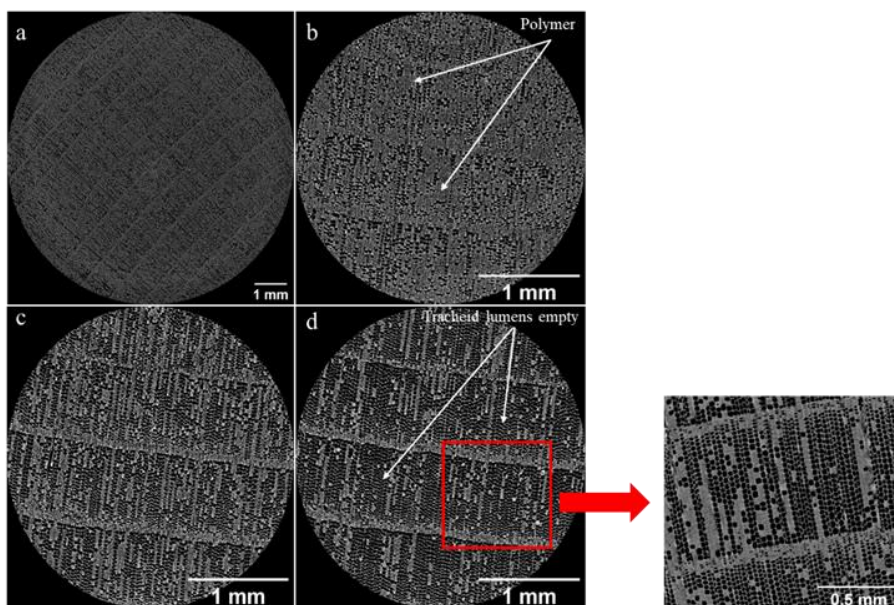

Fig. 5. 2D images of cylindrical sample treated by the vacuum impregnation method

Figure 5a shows the 2D image at a depth of 0.352 mm from the surface. The image shows the tracheid lumens were filled with the polymer. Figure 5b also shows a high percentage of tracheid lumens were filled with the polymer at a depth of 0.508 mm from the surface. Figure 5c and 5d show a decrease in the percentage of tracheid lumens filled with the polymer at a depth of 0.860 mm and 1.270 mm from the surface, respectively.

Wood treated by the vacuum impregnation method showed a higher penetration depth compared to wood treated by the capillary impregnation method. The penetration depth was higher in the transverse plane (longitudinal direction) than in the radial plane. This result is in agreement with those of Emaminasab *et al.* (2017) and Ahmed and Chun (2011), which indicates that the longitudinal penetration is higher than the radial because of the cell arrangement, such as vessels, wood fibers, and axial parenchyma. In other words, in-plane transverse flow of fluids takes place more easily due to lower barriers in comparison to in-plane radial flow. The lower polymer penetration in spruce species is also explained because to large number of the bordered pits are aspirated during wood drying. This occurs as a result of pressure differences between the tracheids (Lehringer *et al.* 2009). Figure 6 shows the 3D images reconstructed from of the 2D images. Figure 6 shows the penetration depth of polymer inside wood, which was non-uniform, however, which was higher than that obtained by Lafond *et al.* (2016). The penetration depth in the transverse plane was clearly visible (Fig. 6a), while in the radial plane, the penetration depth was only superficial (Fig. 6b).

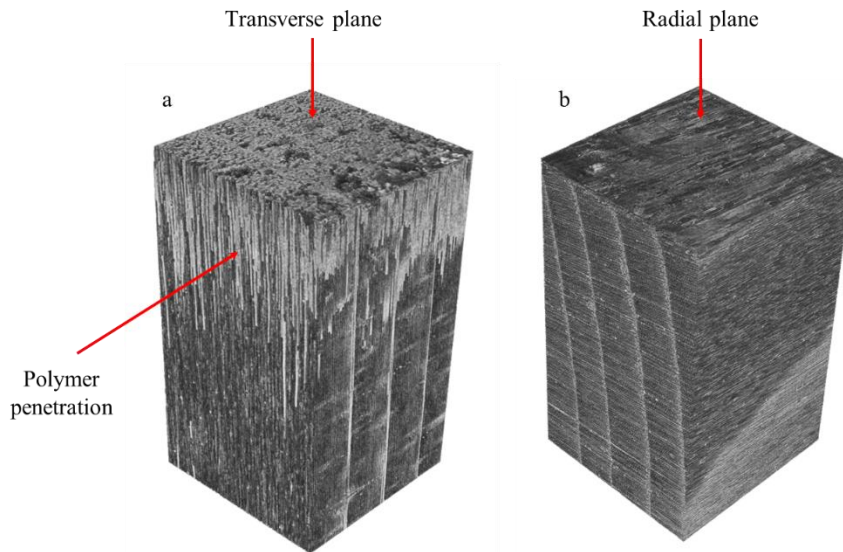

Fig. 6. 3D volume reconstruction of samples treated by the vacuum impregnation method: a) sample treated in the transverse plane; b) sample treated in the radial plane

Dowel-bearing Strength

The dowel-bearing strength was determined following the ASTM D5764-97a (2018) standard. Table 2 shows the statistical results for the first design. The effects of wood treatment and bolt diameter were highly significant ($p < 0.01$) relative to the dowel-bearing strength average values. The analysis included the evaluation of the effect of the specific gravity as a covariance on the results obtained. Previous studies reported a positive correlation between embedding strength and wood specific gravity (Sawata and Yasumura 2002). For this study, statistical analysis showed that the specific gravity did not

significantly influence in the variables studied (Table 2). Table 3 shows the dowel-bearing strength results of test specimens in the parallel direction to the grain. The dowel-bearing strengths of test specimens for both wood treatments (T1 and T2) were higher compared to the untreated test specimens. The results showed the improvement of 13 to 18% with capillary wood treatment (T1) and 19 to 25% with vacuum wood treatment (T2). The wood treatment effect increased with the increase of bolt diameter, in opposition to the results reported by Lafond *et al.* (2017). The higher improvement was observed in test specimens with a D3 bolt diameter. The dowel-bearing strength increased from 25.9 to 32.4 MPa with the vacuum impregnation method. With the capillary impregnation method, the strength increased from 25.9 to 30.6 MPa.

Table 2. Effect of Dependent Variables on the Dowel-bearing Strength and Stiffness (ks) in Parallel Direction

Source	Dowel-bearing Strength (Value F)	Stiffness (Value F)
Design 1		
Specific Gravity	0.03 ^{NS}	1.84 ^{NS}
Wood Treatment	104.76 ^{**}	33.48 ^{**}
Bolt Diameter	22.58 ^{**}	162.66 ^{**}
Wood Treatment × Bolt Diameter	0.29 ^{NS}	5.52 ^{**}
^{NS} Not significant at 0.05 probability level		
^{**} Significant at 0.01 probability level		

The characteristic values of the dowel-bearing strength were also evaluated. The improvement was greater than the mean values in test specimens with bolt diameters D1 and D2. While in the test specimens with a D3 bolt diameter, the improvement was lower than the average values. The coefficient of variation (COV) of the dowel-bearing strength values was approximately 5% up to 11% for different groups of test specimens treated and untreated (Table 3).

Table 3. Bearing Strength for Each Bolt Diameter and Wood Treatment in the Parallel Direction

Bolt Diameter	Wood Treatment	Bearing Strength in MPa (COV)	Change (%)	Bearing Strength (f5%) in MPa	Change (%)
D1	NT	29.4 (10%)	---	23.5	---
D1	T1	33.2 (9%)	13%	27.0	15%
D1	T2	34.8 (7%)	19%	29.7	27%
D2	NT	28.5 (9%)	---	23.5	---
D2	T1	32.9 (11%)	16%	25.9	11%
D2	T2	35.1 (6%)	23%	30.7	31%
D3	NT	25.9 (5%)	---	23.5	---
D3	T1	30.6 (6%)	18%	26.7	13%
D3	T2	32.4 (9%)	25%	26.5	13%
(COV) : Coefficient of variation					

For the test specimens with D1 and D2 bolt diameters treated with T2, the COVs were lower than the test specimens treated with T1 and untreated. The results showed a good homogeneity for each test specimen group.

Figure 7 shows the effect of bolt diameter in characteristic values of dowel-bearing strength. For untreated test specimens, there was no significant difference between test specimens with bolt diameters D1, D2, and D3. The results obtained were in accordance with the results reported by Franke and Magnière (2014b) and Lafond *et al.* (2017). However, Madsen (2000) indicated an increase of bearing strength by the decrease in bolt diameter for a same wood thickness, which gives the assembly good ductility before failure. The effect of bolt diameter in dowel-bearing strength for test specimens treated by the T1 and T2 treatment did not show a clear trend demonstrated in Fig. 7. In general, the wood treatment by the vacuum impregnation method was more effective than by the capillary impregnation method. The chemical retention and the penetration depth of the polymer may explain these results. Both factors were more important in test specimens treated with the T2 method compared to those treated with the T1 method.

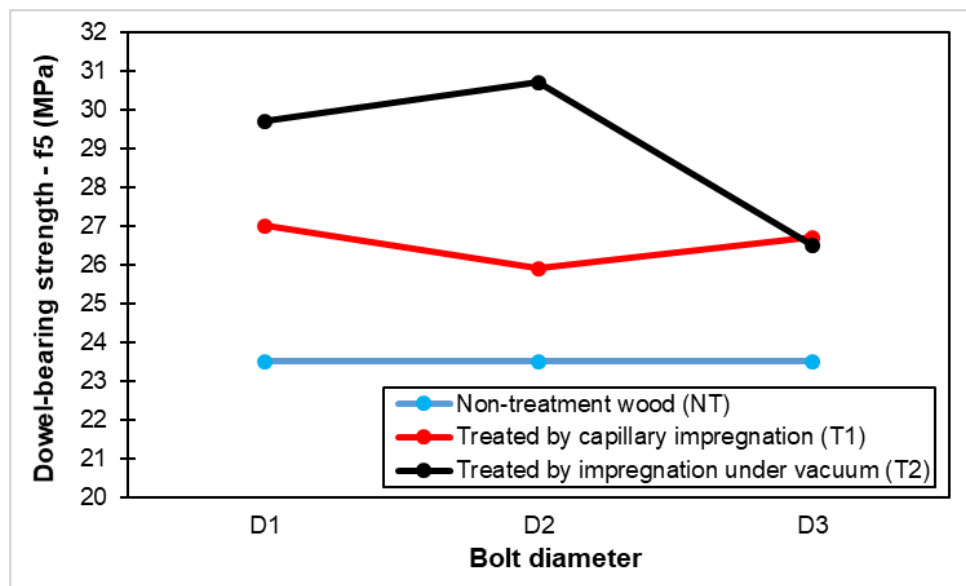

Fig. 7. Evolution of the dowel-bearing strength with the bolt diameter for each wood treatment (NT, T1, and T2)

The stiffness values (average and characteristic values) of the test specimens in each group were also evaluated (Table 4). The results of the stiffness tests were based on the variation in wood treatment and bolt diameter for a load applied parallel to the grain. The treated test specimens showed an improvement in the stiffness of the connection areas compared to the untreated test specimens. The improvement in stiffness was approximately 52%, an increase from 11476 to 17473 N/mm for test specimens treated by the vacuum impregnation method (T2) and a bolt of diameter D2. This improvement was lower for test specimens with different bolt diameters (D1 and D3). The improvement in characteristic stiffness values was also greater than the average values. The improvement was about 97% for the test specimens treated by vacuum wood treatment (T2) with bolt diameter D2.

Table 5 shows the statistical results of the second design, which evaluated the effect of wood treatment and of load direction on test specimens with bolt diameter D2. The effect of each factor was highly significant, as was the interaction between them.

Table 4. Stiffness Values for Each Diameter and Treatment in the Parallel Direction

Bolt Diameter	Treatment	Stiffness in N/mm (COV)	Change (%)	Stiffness (f5%) in N/mm	Change (%)
D1	NT	10001 ^{Aa} (21%)	---	5759	---
D1	T1	11446 ^{Ab} (15%)	14%	8086	40%
D1	T2	12261 ^{Ab} (14%)	23%	8910	55%
D2	NT	11476 ^{Ba} (21%)	---	6688	---
D2	T1	13961 ^{Bb} (13%)	22%	10377	55%
D2	T2	17473 ^{ABc} (12%)	52%	13189	97%
D3	NT	16831 ^{Ca} (20%)	---	10218	---
D3	T1	18648 ^{Cab} (15%)	11%	13127	29%
D3	T2	19114 ^{Bb} (19%)	14%	11751	15%

Averages followed by the same letter are not significantly different at 0.05 probability level. Uppercase letters are for comparison between bolt diameters for each wood treatment. Lowercase letters are for comparison between wood treatments for each bolt diameter. COV: coefficient of variation. (f5%): the characteristics values (5th-percentile).

Table 5. Effect of Dependent Variables on the Bearing Strength and Stiffness of Black Spruce (Design 2)

Source	Bearing Strength (Value F)	Stiffness (Value F)
Design 2		
Density	0.0510 ^{NS}	0.62 ^{NS}
Treatment	26.37 ^{**}	47.90 ^{**}
Direction	1487.92 ^{**}	1671.81 ^{**}
Treatment x Direction	9.27 [*]	34.90 ^{**}

* Significant at 0.05 probability level, ** significant at 0.01 probability level, ^{NS} Not significant at 0.05 probability level

Table 6. Dowel-Bearing Strength and Stiffness for Each Wood Treatment in the Parallel and Perpendicular Direction for Bolt Diameter (D2)

T	Direction	Bearing Strength ¹ (MPa)	Change (%)	Bearing Strength (f5%) in MPa	Change (%)	Stiffness ¹ (ks) in N/mm	Change (%)	Stiffness (f5%) in N/mm	Change (%)
NT	0°	28.5 ^{Aa}	---	23.5	---	11476 ^{Aa}	---	6688	---
T1	0°	32.9 ^{Ba}	16%	25.9	11%	13961 ^{Ba}	22%	10377	55%
T2	0°	35.1 ^{Ca}	23%	30.7	31%	17473 ^{Ca}	52%	13189	97%
NT	90°	15.3 ^{Ab}	---	11.7	---	4199 ^{Ab}	---	3209	---
T1	90°	16.0 ^{ABb}	5%	11.7	0.2%	4669 ^{Ab}	11%	3905	22%
T2	90°	17.8 ^{Bb}	16%	13.8	18%	4880 ^{Ab}	16%	3933	23%

Averages followed by the same letter are not significantly different at 0.05 probability level. Uppercase letters (A, B, and C) are for comparison the dowel-bearing strength and stiffness values between wood treatments for each loading direction. Lowercase letters (a, b) are for comparison the dowel-bearing strength and stiffness values between loading directions for each wood treatment. T: treatment

All test specimens showed an improvement in dowel-bearing strength values compared to non-treated specimens. However, the improvement in the direction perpendicular to the grain was lower than in the direction parallel to the grain. These results were in accordance with those reported by Lafond *et al.* (2017), and Sawata and Yasumura (2002). The dowel-bearing strength decreases when the load-to-grain angle increases (Franke and Magnière 2014). Table 6 shows the improvement in dowel-bearing strength in direction parallel and perpendicular to the grain. The dowel-bearing strength of test specimens treated by the capillary impregnation method in the perpendicular direction to the grain increased from 15.3 to 16.0 MPa (5%). For a test specimen treated by vacuum impregnation method, the value increased from 15.3 to 17.8 MPa (16%).

All test specimens including treated and untreated showed a lower stiffness when the load was applied in perpendicular direction to the grain in comparison with parallel direction, which was in accordance with the mechanical properties and wood anisotropy. The wood treatment effect on stiffness values was not significant when the load was applied in perpendicular direction to the grain (90°). Figure 8 shows the effect of the interaction between the wood treatment and loading direction (perpendicular and parallel to the grain) on the dowel-bearing strength and stiffness values for test specimens of bolt diameter D2.

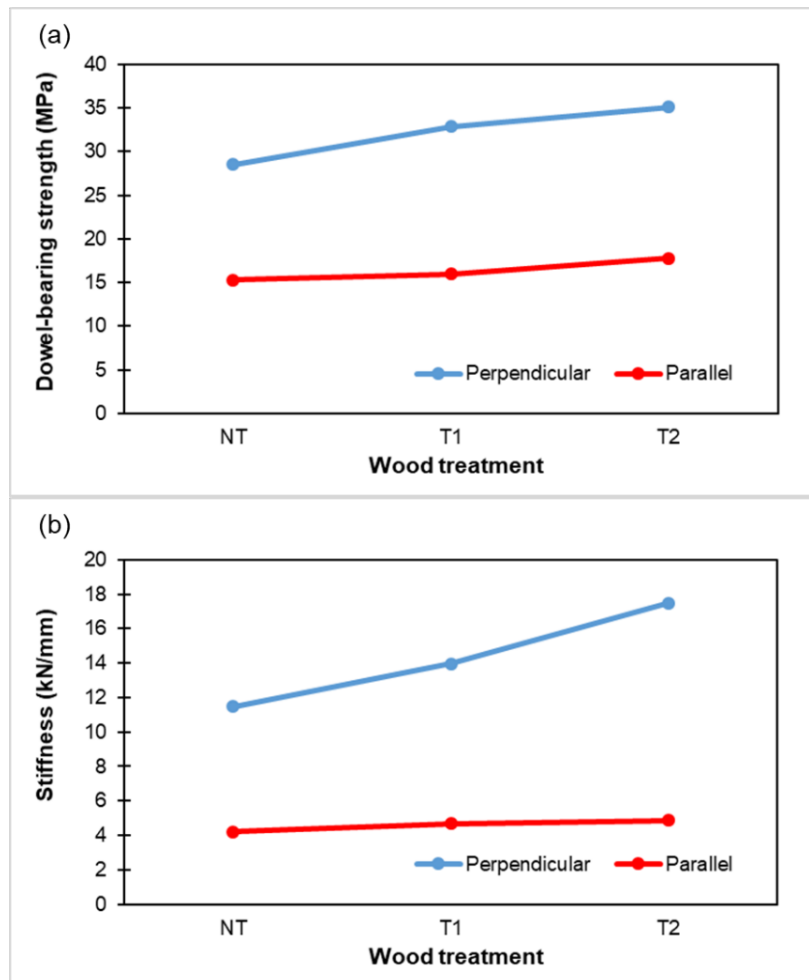

Fig. 8. Interaction between the wood treatment and loading direction on the dowel-bearing strength (a) and stiffness (b) of black spruce for the average values

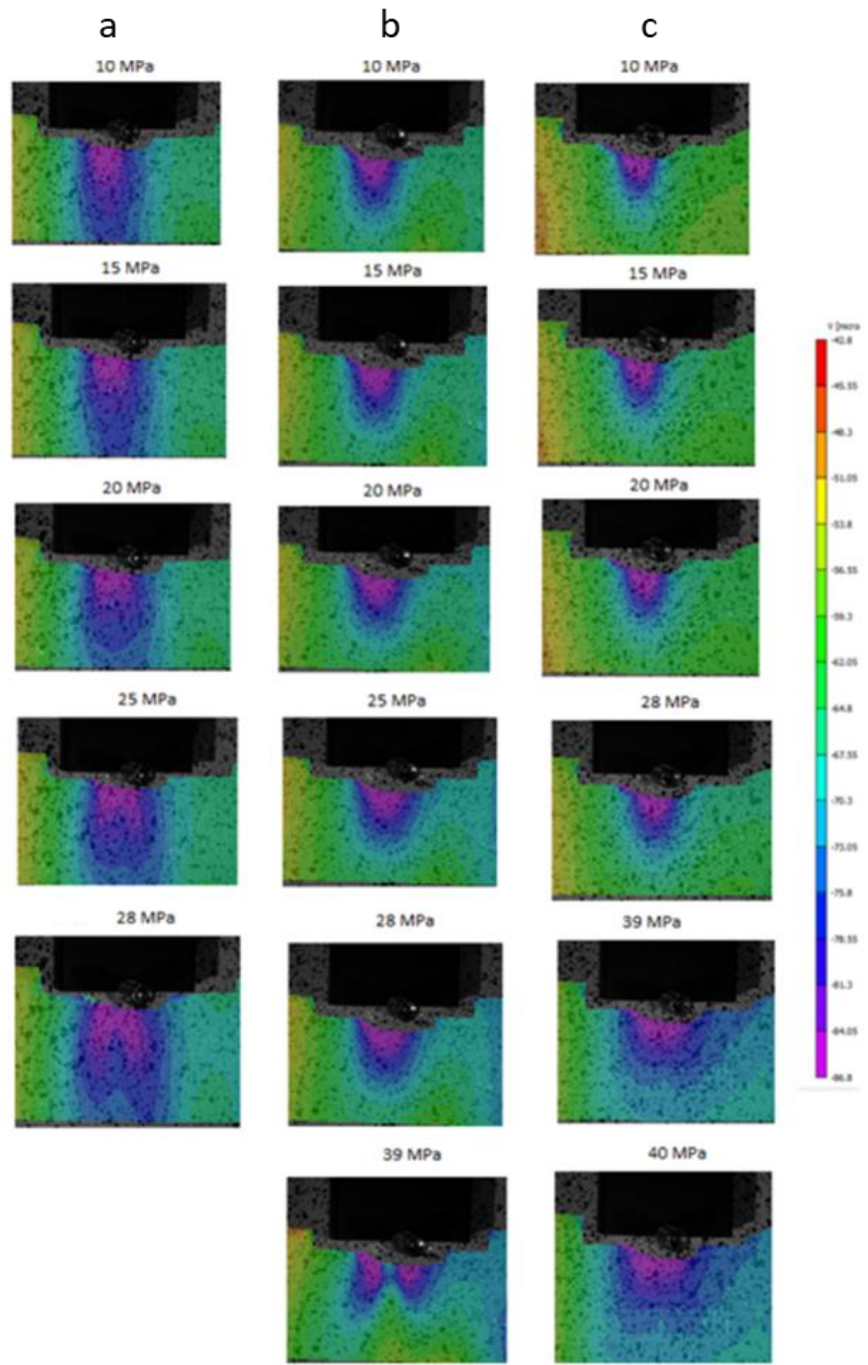

Fig. 9. The deformation field according to the load applied around the assembly area of tests specimens in direction parallel to grain during dowel-bearing test. Column a (non-treated test specimen); Column b (capillary impregnation method); column c (impregnation vacuum method)

The effect of the wood treatments (capillary impregnation method and impregnation vacuum method) in wood deformation was evaluated using digital image correlation. A compressive load increment of 5 MPa to ultimate load was used to illustrate the wood deformation. A color scale was used to display deformations. The deformation levels started at 10 MPa for tests specimen in direction parallel to grain. Figure 9 shows

the image the wood deformation in function of the applied load using Vip-3D software (Correlated Solutions Inc, Irmo, SC, USA).

For non-treated tests specimens, the deformation began to lengthen under the bolt at 5 MPa. As the applied load increased, the deformation field spread horizontally while decreasing longitudinally until the ultimate load of 25 MPa. At this point, the deformation split in two and the wood specimen exhibited the first cracks. By contrast, in the case of treated test specimens the deformation field was less elongated in shape. The deformation was clearly located below the bolt. By increasing of applied load, the deformation increased horizontally while decreasing longitudinally.

CONCLUSIONS

1. The results of dowel-bearing strength tests showed a higher effect of wood treatment as the bolt diameter increased. The characteristic values of bearing strength of wood treated with a bolt diameter of 12.7 mm could increase to 31%, while with a 15.9 mm and 9.5 mm bolt it could increase to 13% and 27%, respectively.
2. Stiffness results showed a greater impact of wood treatment compared to bearing strength results. The higher increase in characteristic values of stiffness after wood treatment was determined for the test specimens using a bolt diameter of 12.7 mm, resulting an improvement of 97%. The improvement in mechanical performance using wood treatment was related to the increase in wood density obtained by the polymerization of the polymer in the tracheal lumens. The effect of the wood treatment in stiffness was more important due to the elastic property of the impregnated polymer.
3. The chemical retention and penetration depth of the polymer were important to achieve an improvement on bearing strength and stiffness. The results demonstrated that the effect of the wood treatment by impregnation under vacuum was significant only when the applied load was parallel to the grain, because the depth of polymer penetration was higher in the transverse plane, while in the radial plane the depth of penetration was superficial.
4. The wood treatment increased the load bearing capacity of timber in the structure. In doing this, it will support a wide use of wood structure as well as allow an optimization of dimensions of the structural component that guided by the connector load bearing capacity.

ACKNOWLEDGMENTS

The authors are grateful to Natural Sciences and Engineering Research Council of Canada for the financial support through its discovery grant, IRC, and CRD programs (RGPIN-2015-05683, IRCPJ 461745-18, and RDCPJ 524504-18) as well as the industrial partners of the NSERC industrial chair on eco-responsible wood construction (CIRCERB).

REFERENCES CITED

- Ahmed, S. A., and Chun, S. K. (2009). "Observation of liquid permeability related to anatomical characteristics in *Samanea saman*," *Turk. J. Agric. For.* 33, 155-163
- Ahmed, S. A., and Chun, S. K. (2011). "Permeability of *Tectona grandis* L. as affected by wood structure," *Wood Sci. Technol.* 45, 487-500.
- ASTM D2395-14 (2014). "Standard test methods for specific gravity of wood and wood-based materials," ASTM International, West Conshohocken, PA, USA.
- ASTM D4442-16 (2016). "Standard test methods for direct moisture content measurement of wood and wood-based materials," ASTM International, West Conshohocken, PA, USA.
- ASTM D5764-97a (2018). "Standard test method for evaluating dowel-bearing strength of wood and wood-based products," ASTM Int., West Conshohocken, PA, USA.
- Bergman, R., Ibach, R. E., LaPasha, C., and Denig, J. (2009). "Evaluating physical property changes for small-diameter, plantation-grown southern pine after *in situ* polymerization of an acrylic monomer," *Forest Products Journal* 59(10), 64-71. DOI: 10.13073/0015-7473-59.10.64
- Cai, X., and Blanchet, P. (2010). "Acrylate wood densification: Effects of vacuum time and nanoparticles on chemical retention, penetration, and resin distribution," *Wood & Fiber Science* 42(3), 318-327.
- Cai, X., and Blanchet, P. (2011). "Effect of vacuum time, formulation, and nanoparticles on properties of surface-densified wood products," *Wood & Fiber Science* 43(3), 326-335.
- Chernenko, V. (2017). "Technology of wood impregnation by polymeric compositions," *Construction of Unique Building and Structures* 7(58), 32-52. DOI: 10.18720/CUBS.58.3
- CSA 086-19 (2019). *Engineering Design in Wood*, Canadian Standard Association, Toronto, Canada.
- Devi, R. R., Gogoi, K., Konwar, B. K., and Maji, T. K. (2013). "Synergistic effect of nanoTiO₂ and nanoclay on mechanical, flame retardancy, UV stability, and antibacterial properties of wood polymer composites," *Polymer Bulletin* 70, 1397-1413. DOI: 10.1007/s00289-013-0928-x
- Devi, R. R., and Maji, T. K. (2013). "Interfacial effect of surface modified TiO₂ and SiO₂ nanoparticles reinforcement in the properties of wood polymer clay nanocomposites," *Journal of the Taiwan Institute of Chemical Engineers* 44(3), 505-514. DOI: 10.1016/j.jtice.2012.11.018
- Emaminasab, M., Tarmian, A., Oladi, R., Pourtahmasi, K., and Avramidis, S. (2017). "Fluid permeability in poplar tension and normal wood in relation to ray and vessel properties," *Wood Science and Technology: Journal of the International Academy of Wood Science* 51(2), 261-272. DOI: 10.1007/s00226-016-0860-y
- Falk, R. (2009). *Wood as a Sustainable Building Material* (FPL/GTR-190), U.S. Dept. of Agriculture, Forest Service, Forest Products Laboratory, Madison, MI, USA.
- Fito, P. (1994). "Modelling of vacuum osmotic dehydration of food," in: *Water in Foods*, Elsevier, pp. 313-328.
- Fito, P., and Pastor, R. (1994). "Non-diffusional mechanisms occurring during vacuum osmotic dehydration," *J. Food Eng.* 21, 513-519.
- Franke, S., and Magnière, N. (2014a). "Discussion of testing and evaluation methods for the embedment behaviour of connections," in: *International Network on Timber*

- Engineering Research*, Bern University of Applied Sciences, Bath, United Kingdom.
- Franke, S., and Magnière, N. (2014b). "The embedment failure of European beech compared to spruce wood and standards," in: *Materials and Joints in Timber Structures*, S. Aicher, H. W. Reinhardt, and H. Garrecht (eds.) RILEM Bookseries, Vol 9, Springer, Dordrecht, Netherlands.
- Frühwald, A. (2007). "The ecology of timber utilization life cycle assessment carbon management etc.," in: Kickoff Meeting CSR, Department of Wood Science and Technology, University of Hamburg, Germany, pp. 1-60.
- Gattesco, N. (1998). "Strength and local deformability of wood beneath bolted connectors," *Journal of Structural Engineering* 124(2), 195-202. DOI: 10.1061/(ASCE)0733-9445(1998)124:2(195)
- Hamideh, A., Mohammad, L., Ghanbar, E., and Mehdi, G. (2014). "Study of stress capacity improvement of l-type joint by chemical modification of wood," *BioResources* 9(3), 5302-5310. DOI: 10.15376/biores.9.3.5302-5310
- Hill, C. A. S. (2006). *Wood Modification: Chemical, Thermal and Other Processes*, John Wiley & Sons, West Sussex, England.
- Jones, D., and Sandberg, D. (2020). "A review of wood modification globally – Updated findings from COST FP1407," *Interdisciplinary Perspectives on the Built Environment*, DOI: 10.37947/ipbe.2020.vol1.1.
- Köhl, M., and Frühwald, A. (2009). "Permanent wood sequestration: No solution to the global carbon dioxide problem," *ChemSusChem* 2, 609-613. DOI: 10.1002/cssc.200800240
- Lafond, C., Blanchet, P., Landry, V., Galimard, P., and Ménard, S. (2016). "The effects of acrylate impregnation of black spruce timber as connectors strength," *BioResources* 11(1), 1753-1764. DOI: 10.15376/biores.11.1.1753-1764
- Lafond, C., Blanchet, P., Galimard, P., Landry, V., and Ménard, S. (2017). "Impact of a reinforcement treatment with acrylate impregnation on the mechanical behavior of black spruce as connector member," *Construction and Building Materials* 141, 517-525. DOI: 10.1016/j.conbuildmat.2017.03.028
- Lehringer, C., Richter, K., and Militz, H. (2009). "Review on promising approaches for liquid permeability improvement in softwoods," *Wood and Fiber Sciences* 41(4), 373-385
- Li, J., Li, Y. F., Meng, X., and Liu, Y. X. (2010). "Durability of wood-PMMA composite," *Applied Mechanics and Materials* 26-28, 830-834. DOI: 10.4028/www.scientific.net/amm.26-28.830
- Madsen, B. (2000). *Behaviour of Timber Connections*, Timber Engineering Ltd., Vancouver, Canada.
- Mungwa, M., Jullien, J. F., Foudjet, A., and Hentges, G. (1999). "Experimental study of a composite wood-concrete beam with the INSA-Hilti new flexible shear connector," *Construction and Building Materials* 13(7), 371-382. DOI: 10.1016/S0950-0618(99)00034-3
- Pantelides, C. P., Romero, P., and Reaveley, L. D. (2010). "Rehabilitation of splice connections of wood trusses with FRP composites," *Construction and Building Materials* 24(1), 37-45. DOI: 10.1016/j.conbuildmat.2009.08.007
- Panarese, V., Herremans, E., Cantre, D., Demir, E., Vicente António, Gómez Galindo Federico, Nicolai, B., and Verboven, P. (2016). "X-ray microtomography provides new insights into vacuum impregnation of spinach leaves," *Journal of Food Engineering* 188, 50-57. DOI: 10.1016/j.jfoodeng.2016.05.013

- Perré, P. (1987). "Measurements of softwoods' permeability to air: Importance upon the drying model," *International Communications on Heat Mass Transfer* 14(5), 519-529. DOI: 10.1016/0735-1933(87)90016-9
- Pizzi, A., Despres, A., Mansouri, H. R., Leban J. M., and Rigolet, S. (2006). "Wood joints by through-dowel rotation welding: Microstructure, ¹³C-NMR and water resistance," *Journal of Adhesion Science and Technology* 20(5), 427-436. DOI: 10.1163/156856106777144327
- Rahman, M. R. (2018). "Characterization of *N,N*-dimethylacetamide impregnated wood polymer nanocomposites (WPNCs)," *Wood Polymer Nanocomposites, Engineering Materials*, 103-121. DOI 10.1007/978-3-319-65735-6_5
- Rahman, M. R., Hamdan, S., Ahmed, A. S., and Islam, M. S. (2010). "Mechanical and biological performance of sodium metaperiodate-impregnated plasticized wood (PW)," *BioResources* 5(2), 1022-1035.
- Rodd, P. D., and Leijten, A. J. M. (2003). "High-performance dowel-type joints for timber structures," *Progress in Structural Engineering and Materials* 5(2), 77-89. DOI: 10.1002/pse.144
- Rowell, R. M. (2012). *Handbook of Wood Chemistry and Wood Composites* (2nd Ed.), CRC Press, Boca Raton, FL, USA.
- Sawata, K., and Yasumura, M. (2002). "Determination of embedding strength of wood for dowel-type fasteners," *Journal of Wood Science* 48, 138-146. DOI: 10.1007/BF00767291
- Shi, J., Li, J., Zhou, W., and Zhang, D. (2007). "Improvement of wood properties by urea-formaldehyde resin and nano-SiO₂," *Frontiers of Forestry in China* 2(1), article no. 104. DOI: 10.1007/s11461-007-0017-0
- Simsek, H., Baysal, E., and Peker, H. (2010). "Some mechanical properties and decay resistance of wood impregnated with environmentally-friendly borates," *Construction and Building Materials* 24(11), 2279-2284. DOI: 10.1016/j.conbuildmat.2010.04.028
- Sun, B., Wang, X., and Liu, J. (2013). "Changes in dimensional stability and mechanical properties of *Eucalyptus pellita* by melamine-urea-formaldehyde resin impregnation and heat treatment," *European Journal of Wood and Wood Products* 71(5), 557-562. DOI: 10.1007/s00107-013-0700-9
- Tokoroyama, T. (2010). "Discovery of the Michael reaction," *European Journal of Organic Chemistry* 2010(10), 2009-2016. DOI: 10.1002/ejoc.200901130
- Upton, B., Miner, R., Spinney, M., and Heath, L. (2008). "The greenhouse gas and energy impacts of using wood instead of alternatives in residential construction in the United States," *Biomass and Bioenergy* 32(1), 1-10. DOI: 10.1016/j.biombioe.2007.07.001
- Veer, G. (1955). *Contribution à l'étude de l'anatomie et la perméabilité du bois de Picea glauca, Picea rubens et Picea mariana [Contribution to the Study of the Anatomy and the Permeability of the Wood of Picea glauca, Picea rubens and Picea mariana]*, Master's Thesis, Université Laval, Québec, Canada.
- Werner, F., and Richter, K. (2007). "Wooden building products in comparative LCA," *International Journal of Life Cycle Assessment* 12(7), 470-479. DOI: 10.1065/lca2007.04.317

Article submitted: April 15, 2021; Peer review completed: August 21, 2021; Revised version received and accepted: March 7, 2022; Published: March 21, 2022.
DOI: 10.15376/biores.17.2.2598-2614